



25A and 50A Industrial Bi-Directional DC Speed Control Rev 3.2 © 2015 by Motion Dynamics Instructions for Installation and Operation (v1.03)



HAZARD Warning !

The heat sink used in this controller may get extremely hot under heavy loads, please keep fingers away! **ESD Sensitive Device!**



Thank you for purchasing your new controller from Motion Dynamics!

We are extremely proud that for whatever your project you have purchased this controller for, you have chosen us to be a small part of that, so thank you for the opportunity! We hope we serve you well!

Features at a glance:

- Wide voltage range 12.0V-36.0V
- Full Speed Regulation with linear control. Options for multiple input options, including Potentiometers, Joysticks or Hall Effect Devices
- Hand assembled in Australia, utilising a heavy duty industrial grade alloy metal case (case model only)
- Reverse Polarity Protection for main drive circuits, Control circuitry protection, protected against EMF spiking up to 600 Volts!
- Optional Soft start for forward and reverse directions!
- Maximum Continuous Current of 50A (capable of sustaining short burst loads up to 80A!)
- Ultrasonic! High Frequency PWM Removes the “whine” caused by oscillating motor windings, even at low speeds!
- 2 Oz 4 Layer PCB with heavy copper traces for low resistance and high current capacity!
- High Speed, 2 AMP N-Channel Mosfet driver!
- 8x High Current 180 Amp 75V Mosfets with the worlds lowest RDS On in TO-220 (4 for 25A model)
- Four Quadrant motor control
- Regenerative - Power generated from the motor is fed back to the source for longer lasting batteries
- Low voltage driver shutdown, protecting the high speed switching drivers against sagging or failing batteries!
- Internal voltage filtering with Transient Clamping Protection to ensure stable and reliable control at all times!
- Eight Way Terminal Connector; For quick and secure connections, suitable for most terrains!
- External connectors for Hall Effect or Potentiometer, On/Off switch and dual inputs for cable lengths up to 5m!
- Flexible inputs! 1k to 1000K Potentiometers, Joysticks, Hand or Foot throttles, Hall Effect (basically any voltage range from 0-5v!)

Preparing for your first start:

1. **Before powering your controller for the first time, please double check your wiring.** Bad wiring is the number one reason for controller failures. Ensure the motor you are powering up is securely fastened. An unsecured motor starting at full speed can torque twist (jump around on your bench) and tear wires out of connectors and potentially cause harm as well as damage! So please use common sense while testing!
2. Ensure that all your connections are secure and cannot vibrate or pull loose. A poorly fitted wire ripped from a source voltage connection can DESTROY the controller. Check that any adjustable settings are configured correctly (or as closely to optimal positions as possible). You can always fine tune things once the controller is switched on.
3. Use adequate wire! If your wires are too thin they will not carry the current you require and will cause voltage sagging at the controller. This may also cause your wiring to heat up and even ignite! Possibly igniting other flammable materials near your project including fumes from your battery!
4. The main 8 way terminal block has dual connections for each connection. For this you have two options, the first is to run two 25A wires to each connection or the second is to use a thick wire and split the copper into two, then run one to each screw terminal. This is handy if your wire is too thick to fit into a single screw terminal (see page 3 for more details)

Out of the box, your controller will be setup for the control method you selected when ordering. So if you ordered a hall effect throttle with your controller then we will have setup the controller for hall effect. If you ordered a potentiometer then we will have everything setup and ready to run a potentiometer. As a customer, Don't you find it convenient when you can simply plug something in and start using it? So do we.

Available Models

There is only a single hardware revision of this board, but there are [three different control options](#). The A, B and C model selection is made at the time of purchase and comes in the form of a (preinstalled) custom Integrated Circuit (IC). If you ever need to change models after purchase, it is simply a matter of purchasing a new A, B or C module, and fitting it. Instructions for fitting can be found on the last page of this guide.



ONE DIRECTION AT A TIME



Push button Braking
(Momentary)



Push button reverse
(Momentary)



Hall effect OR Potentiometer control!

Model A - (SW1-Reverse, SW2 - Brake, Adjustable Control 0-100%)

This controller model is suitable for [Hall effect throttles](#) or [Potentiometers](#) (Same as Model B). The two switches are momentary types. When pressed, **SW1** toggles the direction from forward to reverse or reverse to forward, Pressing **SW2** instantly applies the electronic brakes. Pressing both **SW1** and **SW2** at once will prioritize the brake over the reversing. The controller saves the direction states, soft start settings and input ranges into memory so when you switch on your settings remain as you set them from the previous switch off or configuration states.



ONE DIRECTION AT A TIME



Toggle Switch for reverse
(Latching Switch)



Hall effect OR Potentiometer control!

Model B - (SW1 OR SW2 -Reverse, Adjustable Control 0-100%)

This controller model is suitable for [hall effect throttles](#) or [Potentiometer](#) (same as model A). The single switch is a LATCHING type (Switch on OR Switch OFF). When switched ON, **SW1** OR **SW2** applies reverse, **SW2** is a mirror of **SW1** on this model and braking is applied at throttle down. Similar to Model A, except reverse mode is only active while SW1 is on. The controller saves the soft start settings and input ranges into memory so when you switch on your settings remain as you set them from the previous switch off or configuration states.

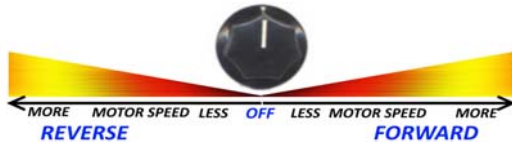

BOTH DIRECTIONS ON ONE CONTROL METHOD



Push Button Braking
(Momentary or Latching switch)



Joystick OR Potentiometer control!

Model C - (SW1 - Brake, SW2 - N/A, Adjustable Control 100%-0-100%)

This model is suitable for [Joystick](#) or [Potentiometer](#) control. It's not good for hall effect unless you have an auto centering hall effect as unlike Model A or B, the direction is controlled directly from the input rather than by using any external switch or button.

For example, your potentiometer turns about 180 degrees. This model splits that into a forward and reverse with reverse being 0-90 degrees and forward being 90-180 degrees. Of course by changing the motor polarity, you can also have 0-90 degrees as forwards and 90-180 as backwards! The single switch is a momentary type. When pressed, **SW1** or **SW2** applies the electronic braking.

The controller saves the soft start settings and input ranges in memory so when you switch on your settings remain as you set them from the previous switch off.

One important feature to note--: Even on models that use either SW1 or SW2, during the programming phase both the buttons are active.

Features common to all models:

Reversible: All models can reverse.

Deceleration Braking: As you throttle back the control method, automatic braking happens which matches your control deceleration.

Regen: is active on ALL models.

Soft start: is available on all models and is active whenever the motor direction changes OR after brake has been applied (Model A, C)

Control Calibration: is available on all models.

Current Limiting: is available on all models.

You can also take a look at our video page on YouTube where you will be able to see each model of the controller with instructional videos on how to use them!

URL: <https://www.youtube.com/user/motiondynamics2010/videos>

Alternatively you can visit page where this controller is listed and simply select the Video tab to check out the instructional video's available for this controller.

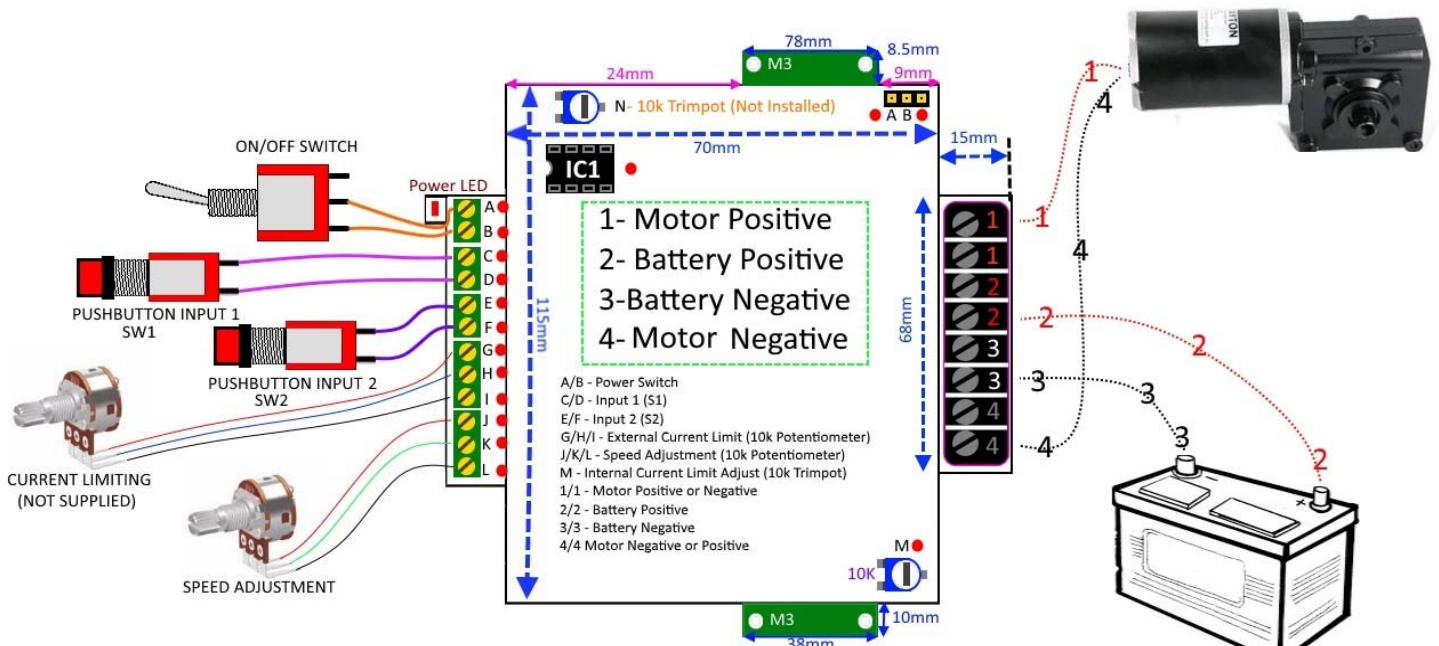

Main Connections (8-way Terminal Block), Why are there 8 connections when only 4 are required?

You will notice that there are two connectors for each connection on this block. 1,1,2,2,3,3,4,4. This is because each screw terminal can only comfortably handle 30A, so attempting to put 50A through a 30A connection isn't smart. For a 25A controller, you only need to use one of each connections, but for a 50A model, you would have to use both because as mentioned it would be unwise to attempt to run 50A through only a single terminal that is rated at 30A. With both connected, they share their current load. (30A + 30A = 60A) For more information see the diagram below! The terminals will accept wire sizes between 12 gauge and 30 gauge.

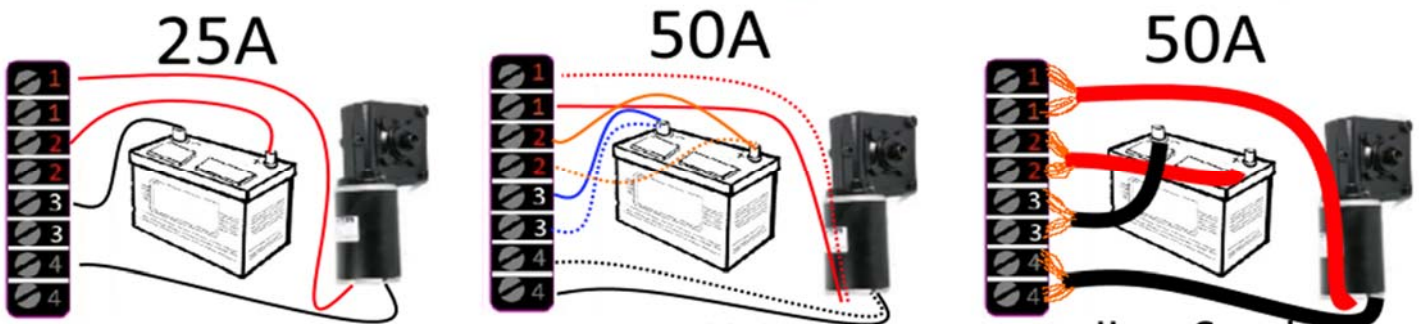

- 1) Motor connection Positive RED or Negative BLACK (depending on which direction you need to motor to go)
- 2) Battery (or Power Supply) Positive
- 3) Battery (or Power supply) Negative
- 4) Motor connection Negative BLACK or Positive RED (depending on which direction you need the motor to go)

Other connections:

A/B—This is where your power switch will connect. Short A & B together to power the controller up. Don't make these wires too long! Note that A/B is also available for use internally if required!

C/D—This is your switch connection (SW1). This was designed for use with a momentary switch. Short C & D out to activate

E/F—This is your switch connection (SW2). This was designed for use with a momentary switch. Short E & F out to activate

G/H/I— This is the external connection for a Potentiometer to control the current limiting (Not Supplied). If you decide to use a 10k pot here, then you will need to remove the 10k Trim pot (M) from the PCB. You cannot use both together. 'G' is +9v, 'H' is the differential output and 'I' is negative battery (ground).

J/K/L— This is the external connection for the 10k potentiometer or Hall effect throttle to control the motor speed (supplied). There is also an option to mount a 10k Trim pot internally (N). You can only ever have one control method installed at any one time, so select either external or internal and stick with that. So if you don't want to use the external 10k Potentiometer, you can always source and install your own 10k Trimpot. 'J' is +5v, 'K' is the differential input (0-5V) and 'L' is negative battery (ground). This is also where you need to connect your hall effect devices. Red (Positive) wire goes to 'J', Black (Negative) wire goes to 'L', Blue/White/Green/Brown (Differential) goes to 'K'

Note that SW1 and SW2 are dependent on which model controller you have. At the time of writing, there are three different models.

The first model uses momentary switches on both SW1 and SW2, where Switch 1 controls the direction and Switch 2 controls the brake.

The second model uses SW1 with a latching switch, which puts the controller into reversing mode (note that with this model there is no SW2)

The third model uses SW1 as a brake and does not use SW2 at all. The reversing is controlled by the input device.

Using your new bi-directional speed controller!

To use, follow these steps.

Power the controller on. When you first power the controller up, it will check whether it needs to go into programming mode. If the programming mode is not set, then it will hand over to manual settings (the settings you currently have set on the control) If the soft start has been enabled, then the soft start will be initialized every time you apply the brake (brake model only) or applied when you go into reverse and will slowly ramp up to the speed set on the speed Potentiometer. If your speed potentiometer is set at 0 (off position) then the controller will simply sit idle, waiting for you to start.

Turn the speed Potentiometer clockwise to increase the speed of the motor. The speed can be adjusted from **OFF** to **Max speed** (and of course, all speeds in-between!).

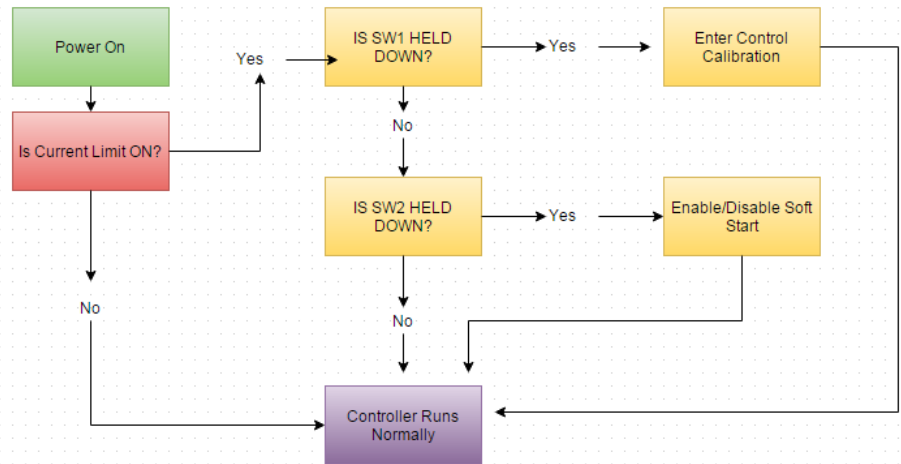

Programming:

The programming mode is extremely simple on this controller and it needs to be because there are no visual cues to follow while setting it up. There are two adjustable options for the programming modes and those are 'Control calibration' and 'Soft Start'.

To turn soft start on or off (this option toggles, if it's ON it will turn OFF, if it's OFF, it will turn ON)

Turn the current limit trim-pot (or potentiometer if you are using that) all the way anti-clockwise. Turn the controller OFF.

Hold down **SW2** WHILE you power the controller ON. Hold it for **FIVE** seconds and release it. If you don't have a button installed there, just short it with wire (use insulated wire, don't touch the wire with your hands)

If the soft start was previously ON, it will now be turned OFF. If it was previously OFF, it will now be turned ON.

Simply repeat when you need the soft start off or on.

You can now re-set your current limit and use the controller as per normal. **If you forget to set the current limit afterwards, the motor won't turn!**

Calibration Mode:

The problem with different control types is the different voltage ranges they all use. While testing Joysticks, Hand Throttles, Foot Throttles, Hall Effect Devices and Potentiometers we noticed that while Potentiometers are always 0-5V, Hall effect devices ALL have different start and end positions. This made the control methods unique, meaning there would be a need for several sub models for each controller based solely on the control method, which would be a nightmare, so the only viable option was to add a calibration mode.

To setup: Plug your control method into the controller and have it ready to go. Turn *the current limit trim-pot (or potentiometer if you are using that) all the way anti-clockwise*. Turn the controller OFF.

Hold down **SW1** while you power the controller ON. After **3 seconds**, release it. If you don't have a button installed there, just short it with wire (use insulated wire, don't touch the wire with your hands)

Now, **quickly** move the throttle back and forth between OFF to full throttle several times. You need to do this quickly as the controller takes hundreds of samples EACH second. While you are moving this, the controller is busy processing your sample data. Keep doing this for 10 seconds. Once the 10 seconds are up, you can re-set your current limit and the controller will be ready to use, but now will use the data you have provided during the calibration.

Once you have set this the data will now be saved.

You can now set your current limit and use the controller as per normal. **If you forget to set the current limit afterwards, the motor won't turn!**

With the calibration, from the moment that you have held the SW1 button for three seconds, it is IMPORTANT that you straight away start the throttle calibration!

Overload Mode:

When the controller senses an overload it will shut down the output for that sample cycle and attempt to restart until the overload condition is gone.

Note that the last 15% of the trimpot adjustment for the current limit (3/4 clockwise) effectively switches ALL current limiting higher than the capacity of the controller! This is because of motors that for a fraction of a second need additional current to start up!

How to set the sensing limits:

Firstly, start by locating the sense trim pot on the controller. It is clearly marked as '**M**'. Once you have found this, start by turning the trim pot all of the way anti-clockwise and set up your motor. Run it at what you would consider your heaviest loading. Start the controller, If the controller shuts down and enters overload mode then the current limit is set too low. Decrease the sensitivity by turning the current sensing trim pot '**M**' clockwise a small amount and wait for the motor to start again. Repeat this process until your motor happily chugs along and the controller no longer enters the overload mode. Now when something goes wrong, it will shut down when it is supposed to.

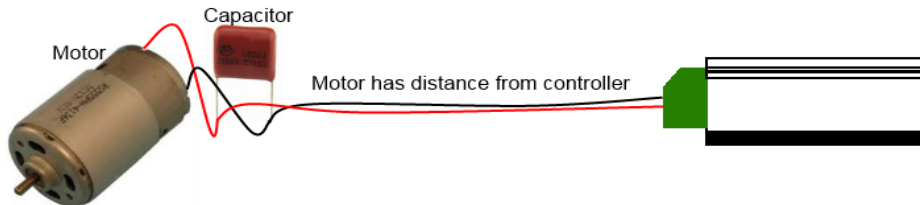

Installation:

(Image above) when you have a motor that is greater than 50CM from the controller, its always smart to add a capacitor to reduce the noise from the motor and sparking from the brushes (adding the capacitor will also greatly increase the life of the brushes). Remember a DC Brushed motor has brushes that, if in poor condition create large sparks (Which are **BAD!** Voltage spikes travel BACK to the controller and must be contained!)

The noise from the motor can also interfere with other circuits that are close by, as the wiring in their circuits pick-up wideband RF directly from the motor. To top it off, without a capacitor installed and by having a long length of wire from the controller to the motor, you'll GREATLY increase the strain on the controller as it attempts to smooth out the noise and remove high voltage spikes and AC introduced by the wiring.

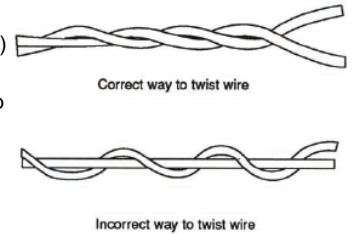

When fitting a capacitor, it needs to be as CLOSE to the motor as possible (even ON the motor is OK!) Always twist the motor and battery wires as shown in the image (above right). NEVER run the wires parallel to each other like figure-8 cable!

Tips and advice:

Keep your motor in good condition! This is one of the most overlooked problems that brushed controllers face. If your motor has a gearbox, then maintain it! Don't be afraid to pull it down to clean and grease it !

- 1) Always make sure your motor brushes are in good condition
- 2) Metallic dirt, if you've ever dropped a magnet on the ground have you noticed all the ground iron that now covers your magnet? This gets into the motor too and creates havoc with DC motors by causing shorts and premature motor wear.
- 3) Over driving your motor with a higher voltage, We never cease to be amazed by the amount of people that think this is OK. Its generally not.

Most motors were never designed to go over the rpm they were built for and this creates all kinds of problems with bearings, armature, premature commutation and brush wear! 4) Never EVER disconnect your motor wires while your motor controller is in operation! Always disconnect from the battery if required in an emergency 5) It's good practice to use an appropriately rated fuse. It wont do anything to protect the controller, because by the time the fuse has even begun to heat up, the damage to the controller has already long been done. At the speed of modern electronics a fuse takes a lifetime to act from the time a problem has actually occurred. The fuse is only there to protect against glowing red hot leads which may lead to a fire.

- 6) Know the current draw of your application! While this seems such an obvious thing to mention, you would be surprised at how little people really know about their motor specifications!
- 7) Always be mindful of your wire lengths! While it may be aesthetically pleasing to take the longest routing around objects for your motor and controller, it creates big problems for your controller. DC is not great with wire length and suffers from massive voltage drops (which is why AC was used for power lines). Keep your wires as short as possible!

Changing the IC to a newer revision:

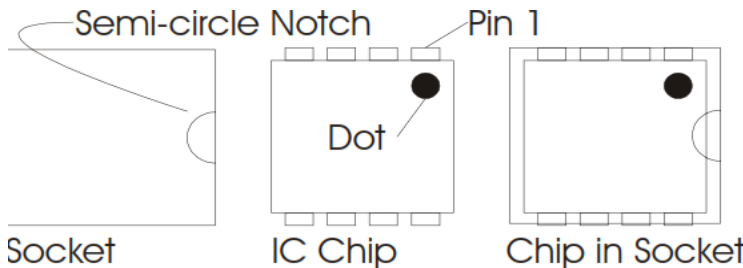

The IC is the brains behind the controller.

The idea behind this controller was to create the hardware as a single piece and allow people to upgrade to later versions (newer revisions) by simply changing the chip (Integrated Circuit) to a newer revision.

In the board you receive, there will be a revision number of the firmware on the IC itself. As we work on new features or fix bugs, the number on the firmware will increase. If you have a bug in your controller, it may we be something we have already addressed, so keep an eye on

the product page to see what revision the current firmware is up to. You will be able to upgrade simply by changing the IC. You can buy the pre-programmed IC directly from us and the picture above shows how the IC must be inserted into the socket. The chip must be inserted correctly and inserting the IC backwards may cause damage to the chip AND the PCB. The dot on the chip must always be on the same side as the notch in the socket.

Look after your controller and it will give you many years of reliable service!

For any questions or support please call Motion Dynamics Australia on 02-96879187

If you have any ideas that we can implement into the controller please feel free to advise us! We can be contacted through: tech@motiondynamics.com.au

We hope whatever projects you undertake, whether for personal or commercial applications, that you will be successful in your endeavors!

This controller is computer controlled. This means that we can make modifications to it, if you require changes.

For example, using one of the inputs for motor feedback or maybe shutting down the controller completely (requiring a power cycle) when an overcurrent situation occurs. There are many changes that we can make. Contact us if you require something specific.